

ALL-STEEL DIE SETS

YAMATO

- スチールダイセット製造・販売 -

大和ダイセット有限公司

〒326-0844 栃木県足利市鹿島町 635-2

TEL . 0284-62-2535(代)

FAX . 0284-62-0733

E-mail: yamato-dieset@nifty.com

URL: <http://yamato-dieset.la.coocan.jp/>

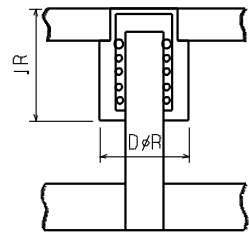
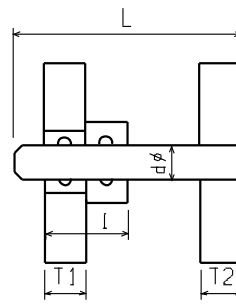
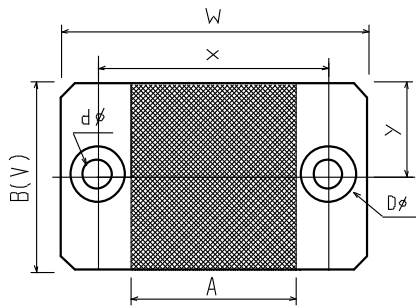

Bプレーンガイド形

Rボールガイド形

CATALOG NUMBER カタログ番号	DIE SPACE 有効面積			W	V	THICKNESS 厚み		d ^φ	L	D ^φ	l	D ^φ _R	l _R	x	y
	A	x	B			T ₁	T ₂								
C1010	100	x	100	210	105	26	30	21	130	42	60	-	-	152	52
C1210	125	x	100	235	105	26	33	24	130	45	70	-	-	175	52
C1510	150	x	100	270	105	30	38	24	140	45	70	49	100	200	52
C1212	125	x	125	235	125	26	33	24	130	45	70	49	100	175	62.5
C1512	150	x	125	270	130	30	38	24	140	45	70	49	100	200	66
C1812	180	x	125	300	130	30	38	24	140	45	70	49	100	230	66
C1515	150	x	150	270	155	30	38	24	140	45	70	49	100	200	78
C1815	180	x	150	300	155	30	38	24	140	45	70	49	100	230	78
C2115	210	x	150	330	155	30	38	24	140	45	70	49	100	260	78
C2515	250	x	150	380	155	30	38	28	150	49	75	54	115	310	78
C3015	300	x	150	440	155	33	38	28	150	49	75	54	115	360	78
C1818	180	x	180	300	185	30	38	24	140	45	70	49	100	230	93
C2118	210	x	180	330	185	30	38	24	140	45	70	49	100	260	93
C2518	250	x	180	380	185	30	38	28	150	49	75	54	115	310	93
C3018	300	x	180	440	185	33	38	28	150	49	75	54	115	360	93
C3518	350	x	180	500	185	33	43	28	150	49	75	54	115	410	93
C2121	210	x	210	340	210	30	38	28	140	49	75	54	115	265	105
C2521	250	x	210	380	210	33	38	28	150	49	75	54	115	305	105
C3021	300	x	210	440	210	33	38	28	150	49	75	54	115	360	105
C3521	350	x	210	500	210	33	43	31	150	54	80	59	115	415	105
C4021	400	x	210	550	210	33	43	31	160	54	80	59	115	465	105
C4521	450	x	210	600	210	38	43	31	160	54	80	59	115	515	105
C5021	500	x	210	660	210	38	43	31	170	54	80	59	115	565	105
C2523	250	x	235	400	235	33	38	28	150	49	75	54	115	315	117.5
C3023	300	x	235	440	235	33	38	28	150	49	75	54	115	360	117.5
C3523	350	x	235	500	235	33	43	31	150	54	80	59	115	415	117.5
C4023	400	x	235	550	235	38	43	31	160	54	80	59	115	465	117.5
C4523	450	x	235	600	235	38	43	31	160	54	80	59	115	515	117.5
C5023	500	x	235	660	235	38	48	36.5	170	64	90	64	115	570	117.5
C5523	720	x	235	720	235	38	48	36.5	170	64	90	64	115	620	117.5
C2526	250	x	260	400	260	33	38	28	150	49	75	54	115	315	130
C3026	300	x	260	450	260	33	43	28	150	49	75	54	115	360	130
C3526	350	x	260	500	260	38	43	31	160	54	80	59	115	415	130
C4026	400	x	260	550	260	38	43	31	160	54	80	59	115	465	130
C4526	450	x	260	600	260	38	43	31	160	54	80	59	115	515	130
C5026	500	x	260	660	260	38	48	36.5	170	64	90	64	115	570	130
C5526	720	x	260	720	260	38	48	36.5	170	64	90	64	115	620	130
C2630	260	x	300	400	300	33	38	28	150	49	75	54	115	320	150
C3030	300	x	300	450	300	33	43	31	150	54	80	59	115	360	150
C3530	350	x	300	500	300	38	43	31	160	54	80	59	115	410	150
C4030	400	x	300	550	300	38	43	31	160	54	80	59	115	465	150
C4430	440	x	300	600	300	38	43	36.5	170	64	90	64	115	510	150
C4830	480	x	300	650	300	38	48	36.5	170	64	90	64	115	550	150
C5330	530	x	300	700	300	43	48	36.5	170	64	90	64	115	595	150
C3035	300	x	350	450	350	38	43	31	160	54	80	59	115	365	175
C3535	350	x	350	500	350	38	43	31	160	54	80	59	115	415	175
C3935	390	x	350	550	350	38	48	31	170	54	80	59	115	455	175
C4435	440	x	350	600	350	38	48	36.5	170	64	90	64	115	510	175
C4935	490	x	350	650	350	43	48	36.5	170	64	90	64	115	560	175
C5235	520	x	350	700	350	43	48	36.5	170	64	90	64	115	600	175
C6635	850	x	350	850	350	43	53	40	190	69	90	69	135	730	175
C4341	430	x	410	600	410	38	48	36.5	170	64	90	64	115	500	205
C4841	480	x	410	650	410	43	48	40	180	69	90	69	135	555	205
C5241	520	x	410	700	410	43	53	40	190	69	90	69	135	590	205
C7142	710	x	410	900	420	48	58	50	200	79	100	79	135	790	210

D型 (DIAGONAL)

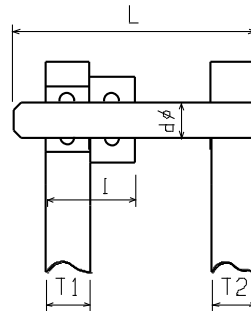
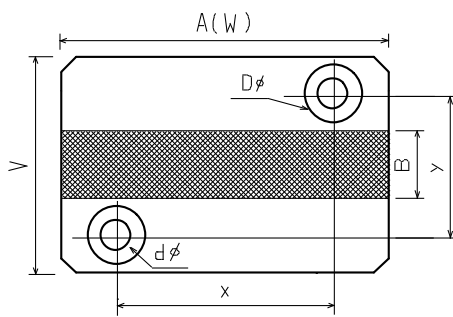

Bプレーンガイド形

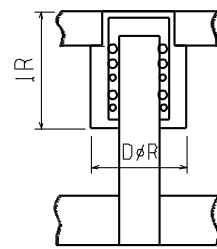

Rボールガイド形

CATALOG NUMBER カタログ番号	DIE SPACE 有効面積 A × B	W	V	THICKNESS 厚み		dφ	L	Dφ	I	Dφ _R	I _R	x	y
				T ₁	T ₂								
D2011	200 × 110	200	235	26	33	24	140	45	70	49	100	130	160
D2511	250 × 110	250	235	30	38	24	140	45	70	49	100	180	160
D3111	310 × 110	310	235	33	38	28	150	49	75	54	115	230	165
D2013	200 × 135	200	260	30	38	24	140	45	70	49	100	130	185
D2513	250 × 135	250	260	30	38	24	140	45	70	49	100	180	185
D3013	300 × 135	300	260	30	38	24	140	45	70	49	100	230	185
D3513	350 × 135	350	260	33	38	28	140	49	75	54	115	270	185
D4013	400 × 135	400	260	33	38	28	140	49	75	54	115	320	185
D4513	450 × 135	450	260	33	43	28	150	49	75	54	115	370	185
D5013	500 × 130	500	260	38	43	31	160	54	80	59	115	420	190
D5513	550 × 130	550	260	38	43	31	160	54	80	59	115	470	190
D3016	300 × 160	300	300	33	38	28	140	49	75	54	115	215	220
D3516	350 × 160	350	300	33	38	28	140	49	75	54	115	265	220
D4016	400 × 160	400	300	33	38	28	140	49	75	54	115	315	220
D4516	450 × 160	450	300	33	43	31	160	54	80	59	115	370	225
D5016	500 × 160	500	300	38	43	31	160	54	80	59	115	420	225
D5516	550 × 160	550	300	38	43	31	160	54	80	59	115	470	225
D6016	600 × 160	600	300	38	43	31	160	54	90	59	115	500	225
D6516	650 × 160	650	300	38	48	31	170	54	90	59	115	550	225
D7016	700 × 160	700	300	43	48	31	170	54	90	59	115	600	225
D3518	350 × 185	350	325	33	38	28	140	49	75	54	115	265	245
D4018	400 × 185	400	325	33	38	28	140	49	75	54	115	315	245
D4518	450 × 185	450	325	33	43	31	160	54	80	59	115	360	245
D5018	500 × 185	500	325	38	43	31	160	54	80	59	115	410	245
D5518	550 × 185	550	325	38	43	31	160	54	80	59	115	460	245
D6018	600 × 185	600	325	38	43	31	170	54	90	59	115	500	250
D6518	650 × 185	650	325	43	48	31	170	54	90	59	115	550	250
D3521	350 × 210	350	350	33	38	28	140	49	75	54	115	270	270
D4021	400 × 210	400	350	33	38	28	140	49	75	54	115	320	270
D4521	450 × 210	450	350	38	43	31	160	54	80	59	115	370	270
D5021	500 × 210	500	350	38	43	31	160	54	80	59	115	416	270
D5521	550 × 210	550	350	38	48	31	170	54	90	59	115	450	275
D6021	600 × 210	600	350	38	48	31	170	54	90	59	115	500	275
D6521	650 × 210	650	350	43	48	31	170	54	90	59	115	550	275
D7021	700 × 210	700	350	43	48	31	170	54	90	59	115	600	275
D4026	400 × 260	400	410	38	43	31	160	54	80	59	115	315	320
D4526	450 × 260	450	410	38	43	31	160	54	80	59	115	360	320
D5026	500 × 260	500	410	38	43	31	160	54	80	59	115	410	320
D5526	550 × 260	550	410	38	48	36.5	170	64	90	64	115	450	325
D6026	600 × 260	600	410	38	48	36.5	170	64	90	64	115	500	325
D5032	500 × 320	500	480	38	48	36.5	170	64	90	64	115	400	385
D5532	550 × 320	550	480	38	48	36.5	170	64	90	64	115	450	385
D6032	600 × 320	600	480	38	48	40	180	69	90	69	115	500	390
D6532	650 × 320	650	480	38	48	40	190	69	90	69	115	550	390

B 型

(BACK)

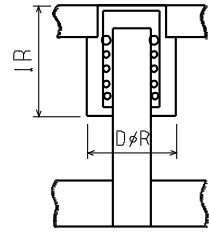
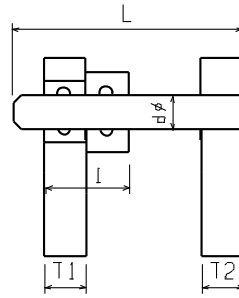
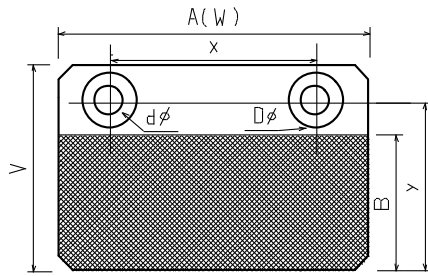
**B** プレーンガイド形**R** ボールガイド形

CATALOG NUMBER カタログ番号	DIE SPACE 有効面積 A × B		W	V	THICKNESS 厚み		d ^φ	L	D ^φ	I	D ^φ _R	I _R	x	y
	T ₁	T ₂												
B1609	160	95	160	155	26	30	21	130	40	60	-	-	95	123
B2109	215	95	215	155	26	33	24	130	45	70	-	-	145	123
B2709	270	95	270	155	30	38	24	140	45	70	49	100	200	123
B2212	220	120	222	180	26	33	24	140	45	70	49	100	150	150
B2712	270	120	270	185	30	38	24	140	45	70	49	100	200	150
B3012	300	120	300	185	30	38	24	140	45	70	49	100	230	150
B2715	270	150	270	210	30	38	24	140	45	70	49	100	200	173
B3415	340	150	340	210	30	38	28	140	49	75	54	115	260	175
B3715	380	150	380	210	33	38	28	140	49	75	54	115	300	175
B2517	250	175	250	235	30	38	24	140	45	70	49	100	180	200
B3117	310	175	310	235	33	38	28	150	49	75	54	115	230	200
B4017	400	175	400	235	33	38	28	150	49	75	54	115	320	200
B2520	250	200	250	260	30	38	24	140	45	70	49	100	180	225
B3020	300	200	300	260	30	38	28	140	49	75	54	115	230	225
B3520	350	200	350	260	33	38	28	140	49	75	54	115	270	225
B4020	400	200	400	260	33	38	28	140	49	75	54	115	320	225
B3023	300	230	300	300	33	38	28	140	49	75	54	115	220	260
B3523	350	230	350	300	33	38	28	140	49	75	54	115	270	260
B4023	400	230	400	300	33	38	28	140	49	75	54	115	320	260
B4523	450	230	450	300	33	43	31	150	54	80	59	115	360	260
B5023	500	230	500	300	33	43	31	160	54	80	59	115	400	260
B3525	350	255	350	325	33	38	28	140	49	75	54	115	270	285
B4025	400	255	400	325	33	38	28	140	49	75	54	115	320	285
B4525	450	255	450	325	33	43	31	160	54	80	59	115	350	285
B5025	500	255	500	325	38	43	31	160	54	80	59	115	400	285
B5525	550	255	550	325	38	43	31	160	54	80	59	115	450	285
B3528	350	280	350	350	33	38	28	140	49	75	54	115	270	310
B4028	400	280	400	350	33	38	28	140	49	75	54	115	300	310
B4528	450	280	450	350	38	43	31	160	54	80	59	115	350	310
B5028	500	280	500	350	38	43	31	160	54	80	59	115	400	310
B5528	550	280	550	350	38	48	36.5	170	64	90	64	115	450	313
B6028	600	280	600	350	38	48	36.5	170	64	90	64	115	480	313
B6527	650	270	650	350	38	48	40	180	69	90	69	130	480	305
B7027	700	270	700	350	38	48	40	180	69	90	69	130	580	305
B6032	600	325	600	410	38	48	40	170	69	90	69	130	480	360
B6532	650	325	650	410	38	48	40	170	69	90	69	130	530	360
B7032	700	325	700	410	38	48	40	180	69	90	69	130	530	360

F 型

(FOUR)

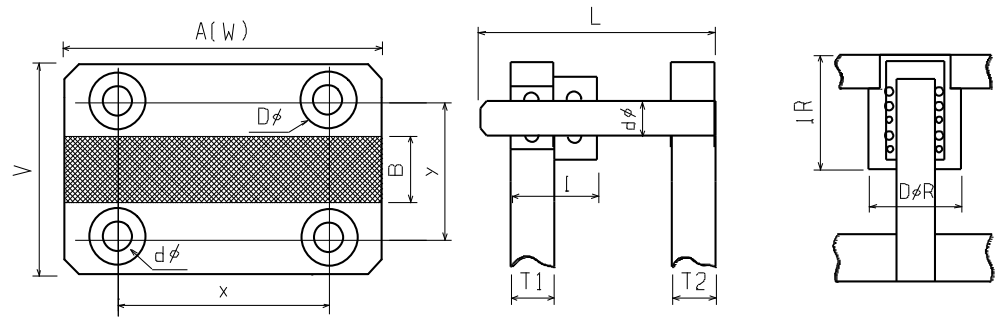

Bブレードガイド形

Rボールガイド形

CATALOG NUMBER カタログ番号	DIE SPACE 有効面積		W	V	THICKNESS 厚み		dφ	L	Dφ	l	Dφ _R	l _R	x	y
	A	B			T ₁	T ₂								
	×	×												
F3013	300	135	300	260	30	38	24	150	45	70	49	100	220	185
F3513	350	135	350	260	33	38	24	150	45	70	49	100	270	185
F4013	400	135	400	260	33	38	24	150	45	70	49	100	310	185
F4513	450	135	450	260	33	43	24	150	45	70	49	100	360	185
F5013	500	130	500	260	38	43	28	160	49	75	54	115	400	185
F5513	550	130	550	260	38	43	28	160	49	75	54	115	450	185
F3017	300	170	300	300	33	38	24	150	45	70	49	100	220	220
F3517	350	170	350	300	33	38	24	150	45	70	49	100	260	220
F4016	400	165	400	300	33	38	28	160	49	75	54	115	300	222
F4516	450	165	450	300	33	43	28	160	49	75	54	115	350	222
F5016	500	165	500	300	38	48	28	170	49	75	54	115	400	222
F5516	550	160	550	300	38	48	31	170	54	80	59	115	440	222
F6016	600	160	600	300	38	48	31	180	54	80	59	115	480	222
F6516	650	160	650	300	43	53	31	180	54	80	59	115	530	222
F4019	400	190	400	325	33	43	28	160	49	75	54	115	300	245
F4519	450	190	450	325	33	43	28	160	49	75	54	115	350	245
F5019	500	190	500	325	38	48	28	170	49	75	54	115	390	245
F5518	550	185	550	325	38	48	31	170	54	80	59	115	440	245
F6018	600	185	600	325	38	53	31	180	54	80	59	115	480	245
F6518	650	185	650	325	43	53	31	180	54	80	59	115	530	245
F7018	700	185	700	325	43	53	31	180	54	80	59	115	560	245
F3521	350	210	350	350	33	43	28	160	49	75	54	115	260	272
F4021	400	210	400	350	33	43	28	160	49	75	54	115	300	272
F4521	450	210	450	350	38	48	28	170	49	75	54	115	350	272
F5021	500	210	500	350	38	48	28	170	49	75	54	115	400	272
F5521	550	210	550	350	38	48	31	170	54	80	59	115	440	272
F6021	600	210	600	350	43	53	31	180	54	80	59	115	480	272
F6521	650	210	650	350	43	53	31	180	54	80	59	115	530	272
F7521	750	210	750	350	43	53	31	180	54	80	59	115	610	272
F8521	850	210	850	350	43	53	31	180	54	80	59	115	690	272
F4027	400	270	400	410	38	48	28	170	49	75	54	115	300	325
F4527	450	270	450	410	38	48	28	170	49	75	54	115	350	325
F5026	500	265	500	410	38	48	31	170	54	80	59	115	380	325
F5526	550	265	550	410	38	48	31	170	54	80	59	115	420	325
F6026	600	265	600	410	38	48	31	170	54	80	59	115	470	325
F6526	650	265	650	410	43	53	31	180	54	80	59	115	520	325
F7026	700	265	700	410	43	53	31	180	54	80	59	115	560	325
F8026	800	260	800	420	43	53	36.5	180	64	90	64	115	660	325
F9026	900	260	900	420	48	58	36.5	200	64	90	64	115	740	325
F10025	1000	250	1000	420	48	58	40	200	69	90	69	130	800	325
F6032	600	320	600	480	48	58	36.5	200	64	90	64	115	480	390
F6532	650	320	650	480	48	58	36.5	200	64	90	64	115	550	390
F7532	750	320	750	480	48	58	36.5	200	64	90	64	115	600	390
F8532	850	320	850	480	48	58	36.5	200	64	90	64	115	690	390
F9531	950	310	950	480	48	58	40	200	69	90	69	130	750	380
F10531	1050	310	1050	480	53	63	40	200	69	90	69	130	850	380
F6537	650	370	650	540	48	58	36.5	200	64	90	64	115	520	440
F7537	750	370	750	540	48	58	36.5	200	64	90	64	115	590	440
F8537	850	370	850	540	48	58	36.5	200	64	90	64	115	690	440
F9537	950	370	950	540	48	58	40	210	69	90	69	130	750	440
F10537	1050	370	1050	540	53	63	40	210	69	90	69	130	850	440

※ご注文は下記の事項をお知らせください。

- ①カタログ番号
- ②ガイドの形式(Bプレーンガイド、Rボールガイド)
- ③製品の板厚
- ④ガイドポストの全長または下死点の間

※ 特注品、各種加工、中抜き、フック、シャンク取付け等、別途承ります。

※ ガイドポストのL寸法およびI寸法については下表からもお選びいただけます。

(下表以外のL寸法でも特注品として承ります)

【ガイドポスト】

《標準タイプ》

d ^φ	L (ガイドポストの全長)																				
21	110	120	130	140	150	160															
24		120	130	140	150	160	170	180	190	200	210										
28		120	130	140	150	160	170	180	190	200	210	220	230	240	250						
31			130	140	150	160	170	180	190	200	210	220	230	240	250	260	270	280	290	300	310
36.5				140	150	160	170	180	190	200	210	220	230	240	250	260	270	280	290	300	310
40		120	130	140	150	160	170	180	190	200	210	220	230	240	250	260	270	280	290	300	310
50					150	160	170	180	190	200	210	220	230	240	250	260	270	280	290	300	310

《脱着タイプ》

d ^φ	脱着S (T _i 上面からの長さ)																			
24	70	80	90	100	110	120	130	140	150	160	170	180								
28		80	90	100	110	120	130	140	150	160	170	180	190	200	210	220				
31		80	90	100	110	120	130	140	150	160	170	180	190	200	210	220	230			
36.5		80	90	100	110	120	130	140	150	160	170	180	190	200	210	220				
40				100	110	120	130	140	150	160	170	180	190	200	210	220	230	240	250	
50	製作注文																			

【ブッシュ】

プレーンブッシュ				ボールブッシュ			
d ^φ	D ^φ	I	T _i に入る部分	d ^φ	D ^φ _R	I _R	T _i に入る部分
21	42	60	23.5	24	49	85	30, 33
24	45	70	25, 30			100	24.5, 30, 33, 36
28	49	75	24.5, 30	28	54	100	30, 33
		85	30			115	30, 33, 36, 42
31	54	75	29.5	31	59	130	30, 33, 36
		80	33			100	30, 33, 36
		90	33			115	30, 33, 36, 42, 46, 51, 56
		100	33			130	33, 36, 42, 46, 51
		120	33, 36			100	33, 36, 42
36.5	64	90	33, 36	36.5	64	115	33, 36, 42, 46, 51, 56
		120	33			130	36, 42, 46, 51, 56
40	69	90	33, 36, 42	40	69	100	36
		120	33			115	36, 42, 46
50	79	100	36, 42, 46	50	79	130	36, 42, 46, 51, 56
						140	36, 42, 46, 50, 56



設備概要



機械名	メーカー名	能力 (mm)	備考
5面加工機 (門型マシニングセンター)	東芝機械	3,500×1,600	パレットチェンジャー付 ATC120本
縦型マシニングセンター	東芝機械	2,000×850	
横型マシニングセンター	東芝機械	800×800	パレットチェンジャー付
平面研削盤	住友重機	3,000×900	N. C. 装置付
平面研削盤	アマダ	1,000×500	
平削盤	北村	3,000×1,500	
円筒研削盤	豊田工機	芯間550	N. C. 装置付
円筒研削盤	豊田工機	芯間550	N. C. 装置付
内面研削盤	トーヨー		N. C. 装置付
内面研削盤	トーヨー		
ラジアルボール盤	吉田	1,100	
フライス盤	日立精機	1,500×500	
治具ボーラー	和井田	650×400	
CAD・CAM	浜松合同	NASUKA	受入データ形式 : DXF、 IGES